

CAM FOLLOWERS

SOLID ECCENTRIC TYPE
HEXAGON SOCKET ON BOTH SIDES
GREASE NIPPLE INSTALLED

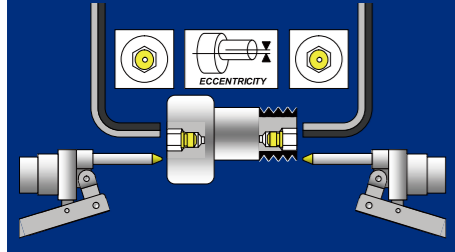

CFH..AB



CFH..VAB

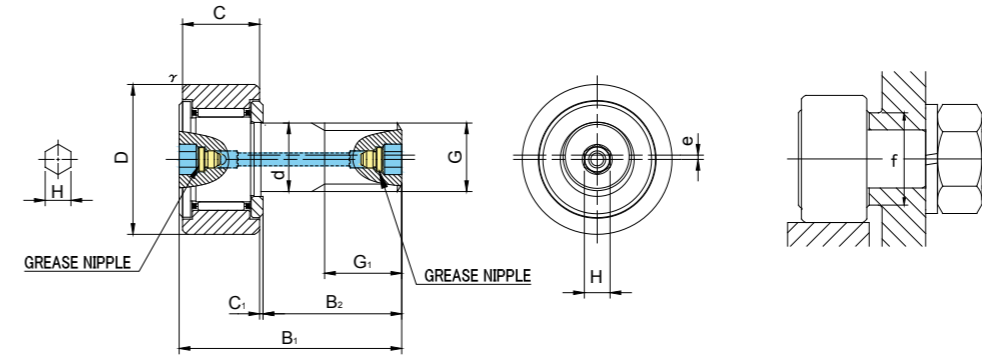

Prepacked Grease

CFH..AB TYPE

Stud diameter (mm)	h7 tolerance	Designation				Dimensions (mm)													Basic dynamic load rating	Basic static load rating	Largest permissible load	Limiting speed *	Track load capacity		Max tightening torque	Mass					
		Cylindrical outer ring		Crowned outer ring R500(CF10 ~ CF18) R1000(CF20 ≤)		D	C	d	G	G1	B1	B2	C1	H	r _s min	e	f min	Cr N					Cor N	N			rpm	Cylindrical outer ring N	Crowned outer ring N	N·m	g (approx)
		Without seals	With seals	Without seals	With seals																										
12	0 -0.018	CFH12AB	CFH12UUAB	CFH12RAB	CFH12UURAB	30	14	12	M12×1.5	13	40	25	0.6	6	0.6	0.4	20	7 940	9 800	9 800	14 000	7 060	2 450	22	95						
		CFH12VAB	CFH12VUUAB	CFH12VRAB	CFH12VUURAB																										
12	0 -0.018	CFH12-1AB	CFH12-1UUAB	CFH12-1RAB	CFH12-1UURAB	32	14	12	M12×1.5	13	40	25	0.6	6	0.6	0.4	20	7 940	9 800	9 800	14 000	7 450	2 740	22	105						
		CFH12-1VAB	CFH12-1VUUAB	CFH12-1VRAB	CFH12-1VUURAB																										
16	0 -0.018	CFH16AB	CFH16UUAB	CFH16RAB	CFH16UURAB	35	18	16	M16×1.5	17	52	32.5	0.8	6	0.6	0.5	24	12 050	18 330	18 330	10 000	11 200	3 140	58	170						
		CFH16VAB	CFH16VUUAB	CFH16VRAB	CFH16VUURAB																										
18	0 -0.018	CFH18AB	CFH18UUAB	CFH18RAB	CFH18UURAB	40	20	18	M18×1.5	19	58	36.5	0.8	6	1	0.6	26	14 700	25 200	25 200	8 500	14 400	3 720	87	250						
		CFH18VAB	CFH18VUUAB	CFH18VRAB	CFH18VUURAB																										
20	0 -0.021	CFH20AB	CFH20UUAB	CFH20RAB	CFH20UURAB	52	24	20	M20×1.5	21	66	40.5	0.8	8	1	0.7	36	20 680	34 600	32 140	7 000	23 200	8 230	120	460						
		CFH20VAB	CFH20VUUAB	CFH20VRAB	CFH20VUURAB																										
20	0 -0.021	CFH20-1AB	CFH20-1UUAB	CFH20-1RAB	CFH20-1UURAB	47	24	20	M20×1.5	21	66	40.5	0.8	8	1	0.7	36	20 680	34 600	32 140	7 000	21 000	7 150	120	385						
		CFH20-1VAB	CFH20-1VUUAB	CFH20-1VRAB	CFH20-1VUURAB																										

CFH..AB TYPE has oil holes (grease nipple) which are prepared in the stud head and thread side, also an oil hole is prepared outer surface of stud.

* Without seals, suitable for grease lubrication. In case of oil lubrication, up to 130% of this value shall be permissible, and 70% of this value shall apply for types with seals.

OUTER RINGS TOLERANCE (μm)

TYPE	Cylindrical outer ring	Crowned outer ring
CF12	0/-9	0/-50
CF12-1,CF16,CF18,CF20-1	0/-11	0/-50
CF20,CF24,CF24-1,CF30	0/-13	0/-50
CF30-1,CF30-2	0/-15	0/-50

ACCESSORIES

TYPE	Grease Nipple	NUT
All types	Installed	Attached

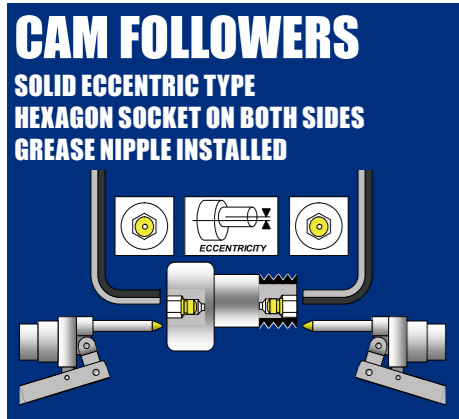

CFH..AB



CFH..VAB

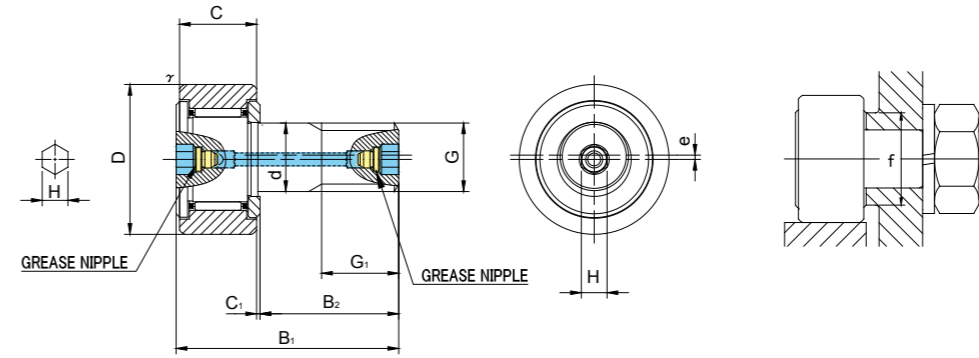

Prepacked Grease

CFH..AB TYPE

Stud diameter (mm)	h7 tolerance	Designation				Dimensions (mm)													Basic dynamic load rating	Basic static load rating	Largest permissible load	Limiting speed *	Track load capacity		Max tightening torque	Mass					
		Cylindrical outer ring		Crowned outer ring R1000(CF24 ≤)		D	C	d	G	G1	B1	B2	C1	H	r _s min	e	f min	Cr N					Cor N	N			rpm	Cylindrical outer ring N	Crowned outer ring N	N·m	g (approx)
		Without seals	With seals	Without seals	With seals																										
24	0 -0.021	CFH24AB	CFH24UUAB	CFH24RAB	CFH24UURAB	62	29	24	M24×1.5	25	80	49.5	0.8	8	1	0.8	40	30 480	52 630	49 500	6 500	34 200	10 500	220	815						
		CFH24VAB	CFH24VUUAB	CFH24VRAB	CFH24VUURAB													46 550	92 020	49 500	3 000										
24	0 -0.021	CFH24-1AB	CFH24-1UUAB	CFH24-1RAB	CFH24-1UURAB	72	29	24	M24×1.5	25	80	49.5	0.8	8	1	0.8	40	30 480	52 630	49 500	6 500	39 800	12 900	220	1 140						
		CFH24-1VAB	CFH24-1VUUAB	CFH24-1VRAB	CFH24-1VUURAB													46 550	92 020	49 500	3 000										
30	0 -0.021	CFH30AB	CFH30UUAB	CFH30RAB	CFH30UURAB	80	35	30	M30×1.5	32	100	63	1	8	1	1	46	45 370	85 060	73 700	5 000	52 600	14 900	450	1 870						
		CFH30VAB	CFH30VUUAB	CFH30VRAB	CFH30VUURAB													67 620	144 060	73 700	2 200										
30	0 -0.021	CFH30-1AB	CFH30-1UUAB	CFH30-1RAB	CFH30-1UURAB	85	35	30	M30×1.5	32	100	63	1	8	1	1	46	45 370	85 060	73 700	5 000	56 000	16 100	450	2 030						
		CFH30-1VAB	CFH30-1VUUAB	CFH30-1VRAB	CFH30-1VUURAB													67 620	144 060	73 700	2 200										
30	0 -0.021	CFH30-2AB	CFH30-2UUAB	CFH30-2RAB	CFH30-2UURAB	90	35	30	M30×1.5	32	100	63	1	8	1	1	46	45 370	85 060	73 700	5 000	59 300	17 300	450	2 220						
		CFH30-2VAB	CFH30-2VUUAB	CFH30-2VRAB	CFH30-2VUURAB													67 620	144 060	73 700	2 200										

CFH..AB TYPE has oil holes (grease nipple) which are prepared in the stud head and thread side, also an oil hole is prepared outer surface of stud.

* Without seals, suitable for grease lubrication. In case of oil lubrication, up to 130% of this value shall be permissible, and 70% of this value shall apply for types with seals.

OUTER RINGS TOLERANCE (μm)

TYPE	Cylindrical outer ring	Crowned outer ring
CF12	0/-9	0/-50
CF12-1,CF16,CF18,CF20-1	0/-11	0/-50
CF20,CF24,CF24-1,CF30	0/-13	0/-50
CF30-1,CF30-2	0/-15	0/-50

ACCESSORIES

TYPE		
All types	Installed	Attached